

**lzf**  
HANDMADE

X-CLUB  
Book

---

pdf

---

2012

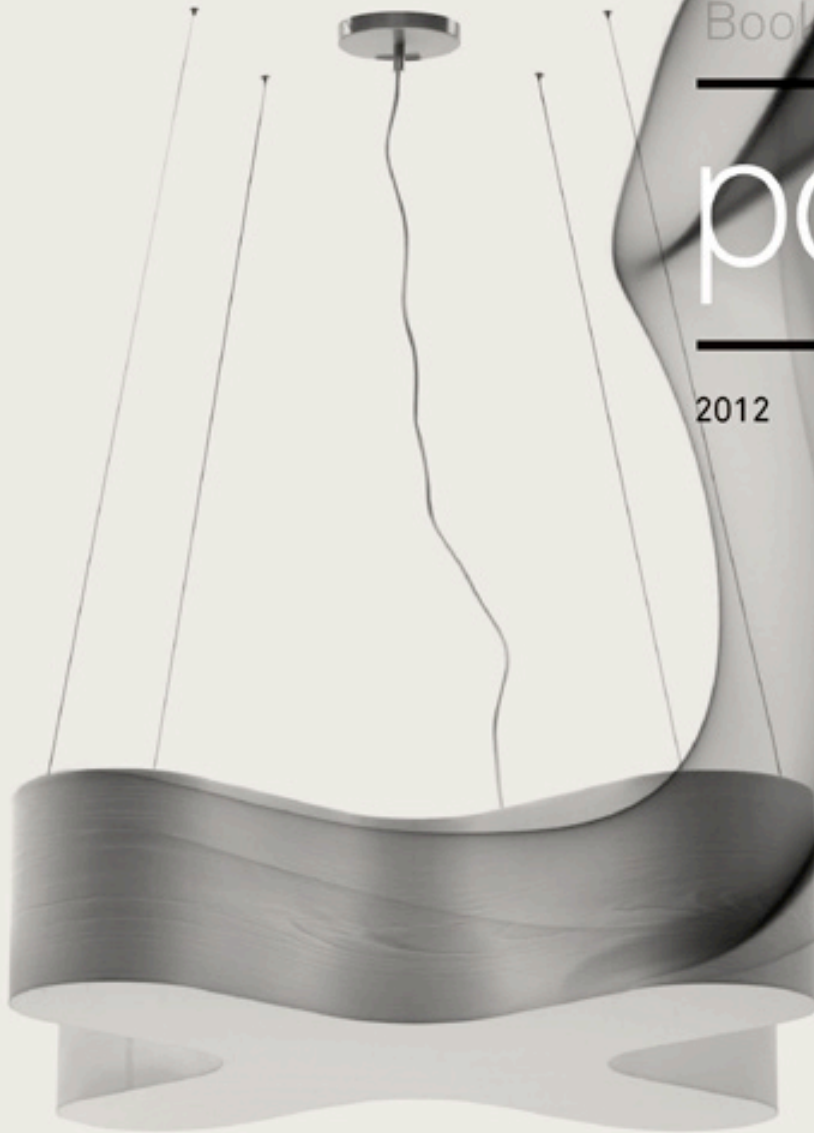

Wood touched by Light





## X-CLUB

---

Burkhard Dämmer

X-Club, distinction and elevation

X-Club is a series created by German designer Burkhard Dämmer featuring a smart combination of direct and indirect lighting, very useful for private interiors, that adapts well to public and commercial areas.

A new version of the Club family, now “x”-shaped, it is easily spotted by its peculiar volume that immediately attracts all the looks; X-Club-S is a hanging sculpture that, like other LZf lamps, can be used in combination with other models.

All the versions of this series incorporate state-of-the-art electronic technology that guarantees a minimum electrical consumption.

### **X-Club, distinción y elevación**

*X-Club es una familia diseñada por el alemán Burkhard Dämmer, quien ingenió una sabia combinación de luz directa e indirecta, útil para espacios privados y para ambientes públicos o comerciales.*

*Es una reinterpretación de la familia Club, en esta ocasión, en forma de “x”; es precisamente ese volumen identificable el que le da tanta personalidad; consigue atrapar las miradas de todos. Una auténtica escultura suspendida, que como en otras lámparas de LZf, puede combinarse en un mismo espacio con más modelos.*

*Todas las versiones de esta familia incluyen una tecnología electrónica que asegura un mínimo consumo energético.*

X-CLUB Burkhard Dämmer

SUSPENSION  
SUSPENSIÓN

INFO

Electrical

Packaging

Dimension

X S CHW



Shade / Pantalla

Natural wood  
**Madera natural**  
CHW colors:



see chart / ver gráfico

Diffuser / Difusor  
opal acrylic /  
**metacrilato opal**

Consult for price  
on dimable version  
Electronic ballast  
Dali compatible/

**Consultar precio  
para versión dimable**  
**Balastro electrónico**  
**Dali compatible**

Family / Familia  
pendant, table  
and wall /  
**susp, mesa  
y aplique**

WORLD

2 x 14 w  
T-5  
linear fluorescent  
included /  
**fluorescente lineal  
incluido**

USA

2 x 14 w  
T-5  
linear fluorescent  
not included  
110v - 277v  
multivolt ballast



Box / Caja:  
7,6 Kg  
0,225 m<sup>3</sup>  
75x75x40 cm

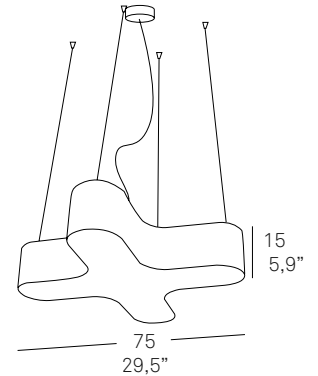

X SG CHW



WORLD

2 x 21 w  
T-5  
linear fluorescent  
included /  
**fluorescente lineal  
incluido**

USA

2 x 39 w  
T-5  
linear fluorescent  
not included  
110v - 277v  
multivolt ballast



Box / Caja:  
16 Kg  
0,422 m<sup>3</sup>

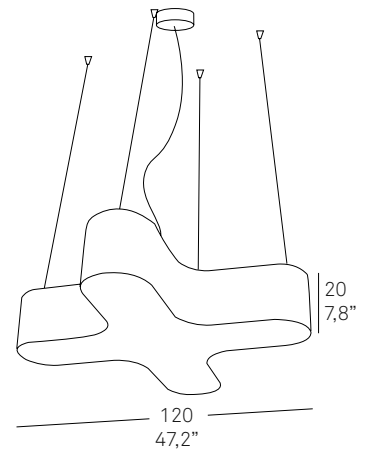

X-CLUB Burkhard Dämmer

FLOOR PIE

X MG CHW



**Shade / Pantalla**  
 Natural wood  
**Madera natural**  
 CHW colors:  
 20 21 22 24  
 25 26 27 29  
 see chart / ver gráfico

**Diffuser / Difusor**  
 opal acrylic /  
**metacrilato opal**

**WORLD**  
 2 x 21 w  
 T-5  
 linear fluorescent  
 included /  
**fluorescente lineal  
 incluido**

**USA**  
 2 x 14 w  
 T-5  
 linear fluorescent  
 not included  

**Box / Caja:**  
 16 Kg  
 0,422 m<sup>3</sup>  
 101x102x41 cm

36 Lb  
 Box size:  
 40x40x16"

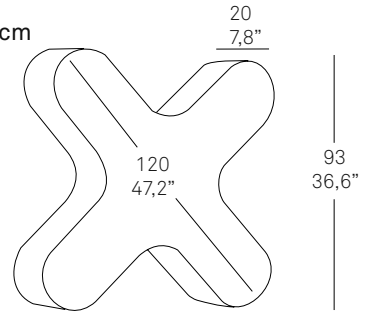

TABLE MESA

X M CHW



Consult for price  
 on dimable version  
 Electronic ballast  
 Dali compatible/  
**Consultar precio  
 para versión dimable**  
**Balastro electrónico**  
**Dali compatible**

**Family / Familia**  
 pendant, table  
 and wall /  
**susp, mesa  
 y aplique**

**WORLD**  
 2 x 14 w  
 T-5  
 linear fluorescent  
 included

**USA**  
 2 x 21 w  
 T-5  
 linear fluorescent  
 not included  

**Box / Caja:**  
 7,5 Kg  
 0,225 m<sup>3</sup>  
 75x75x40 cm

17 Lb  
 Box size:  
 30x30x16"

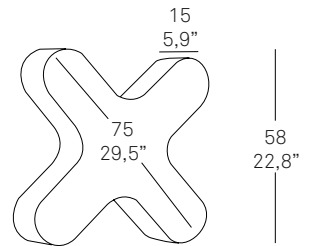

WALL APLIQUE

X A CHW



**WORLD**  
 2 x 14 w  
 T-5  
 linear fluorescent  
 included

**USA**  
 2 x 14 w  
 T-5  
 linear fluorescent  
 not included  
 110v - 277v  
 multivolt ballast  

**Box / Caja:**  
 8,5 Kg  
 0,225 m<sup>3</sup>  
 75x75x40 cm

19 Lb  
 Box size:  
 30x30x16"

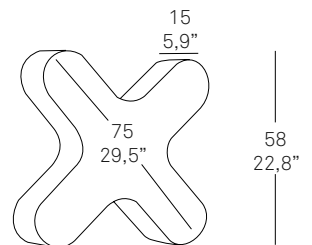

**X-CLUB** Burkhard Dämmer

FAMILY / FAMILIA

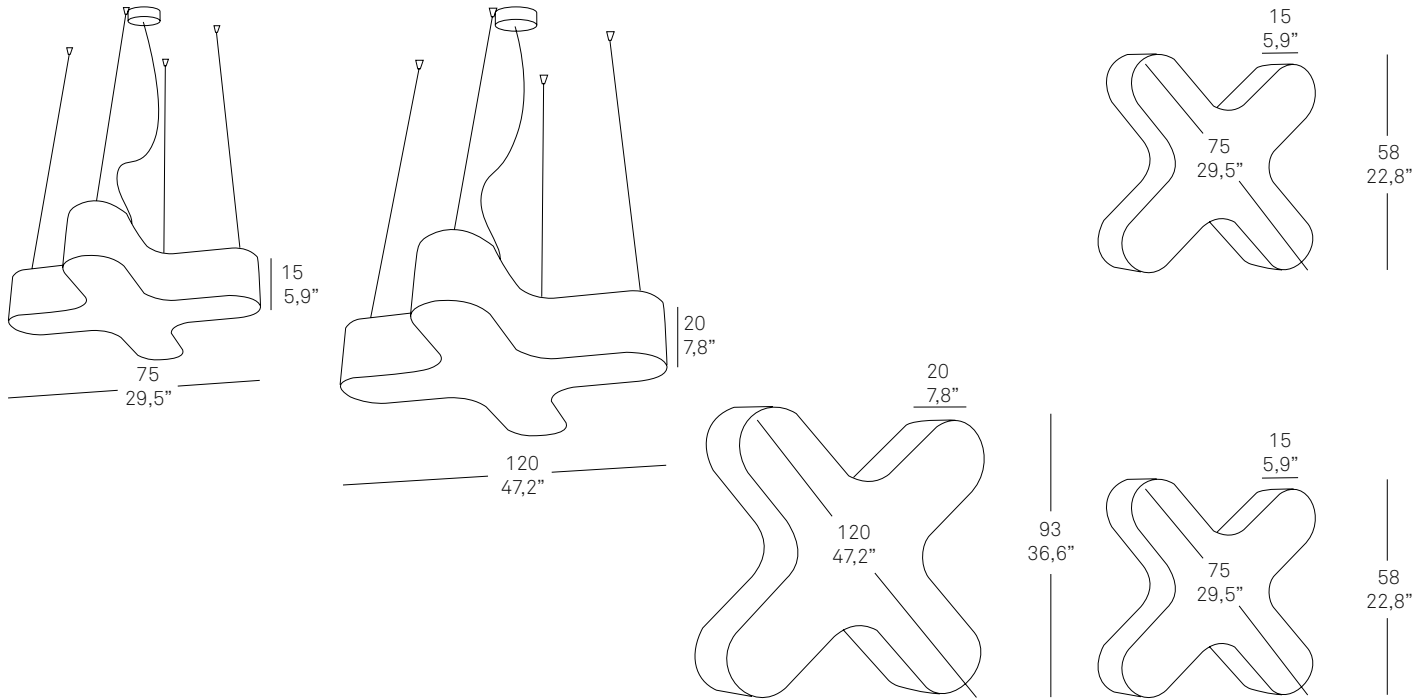

SHADE FINISHES / ACABADOS PANTALLAS

REF. CHW

Natural timber veneer **Madera natural**

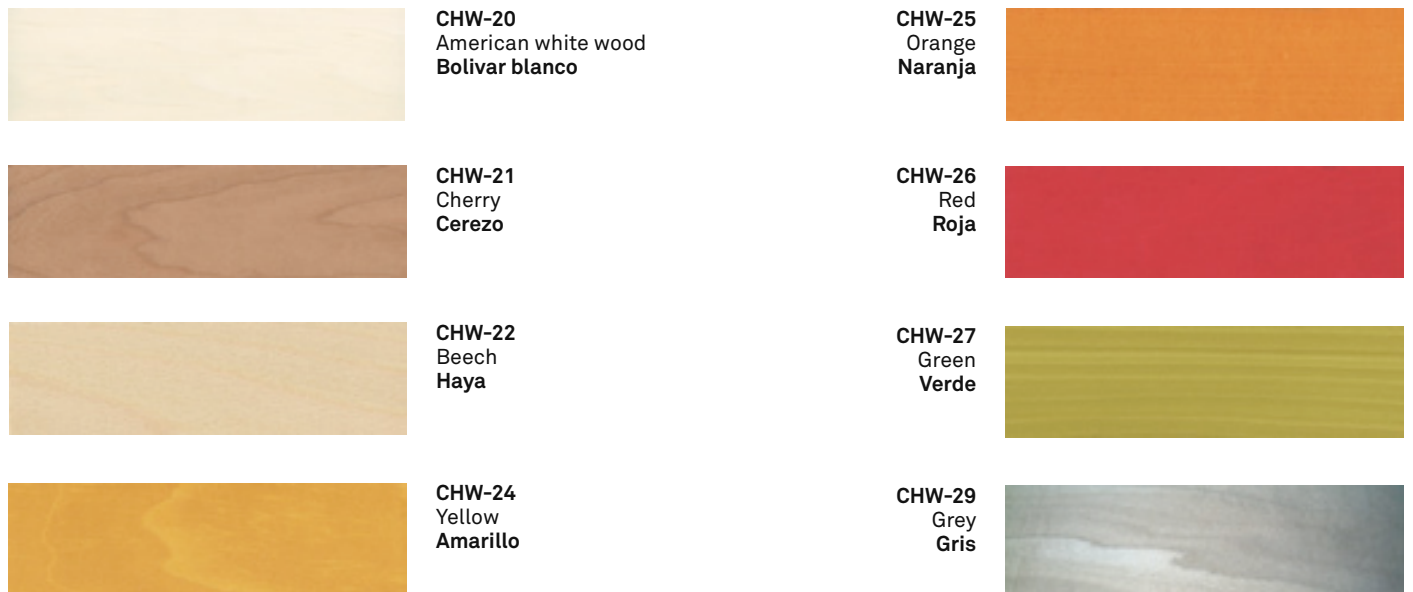





**X-Club**  
Burkhard Dämmer



**X-Club**  
Burkhard Dämmer





**X-Club**  
Burkhard Dämmer

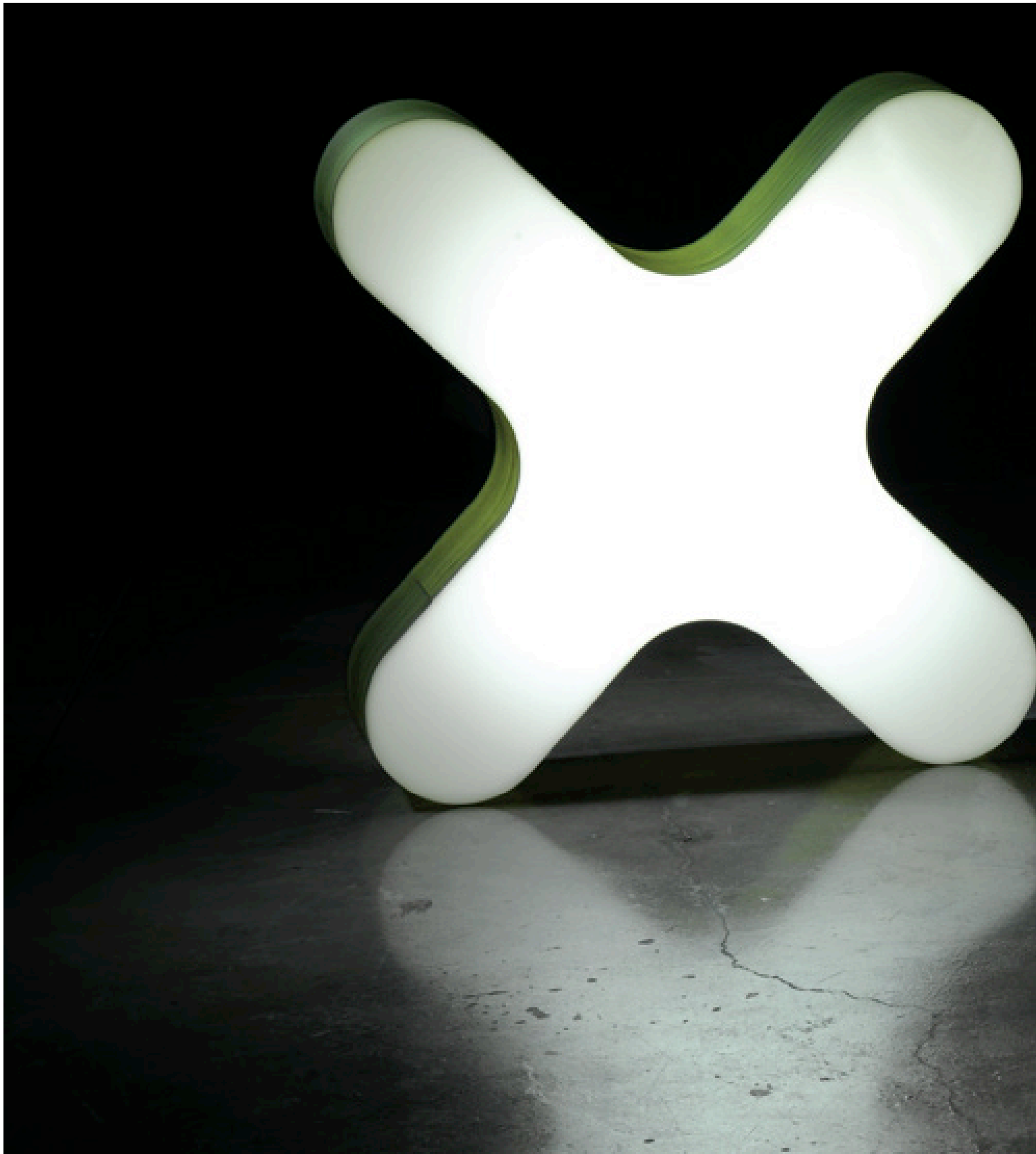

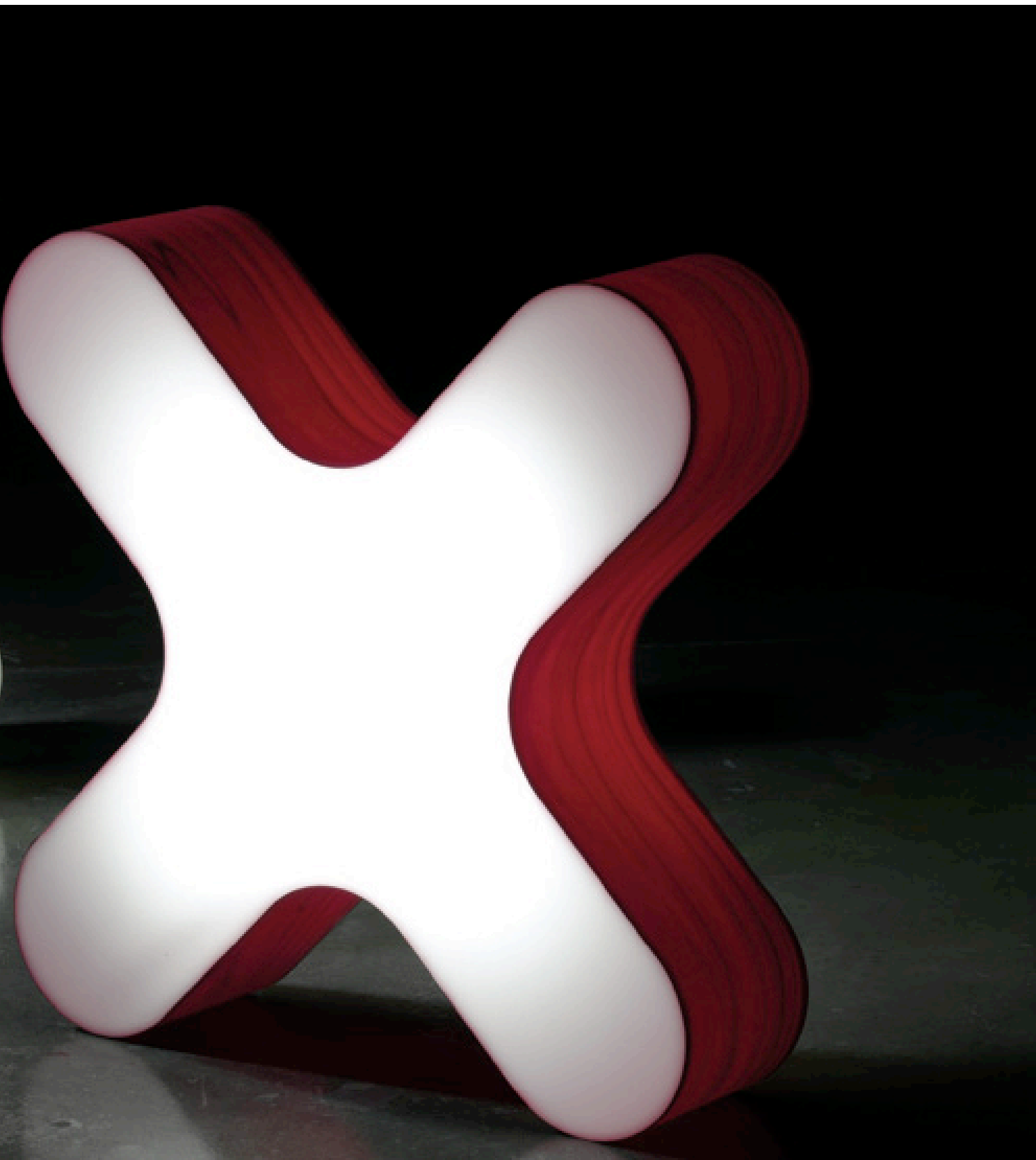

**X-Club**  
Burkhard Dämmer







SPANISH  
ARTISAN  
OF THE YEAR  
AWARD 2011