

lzf  
HANDMADE

SIoux  
Book

---

pdf

---

2012

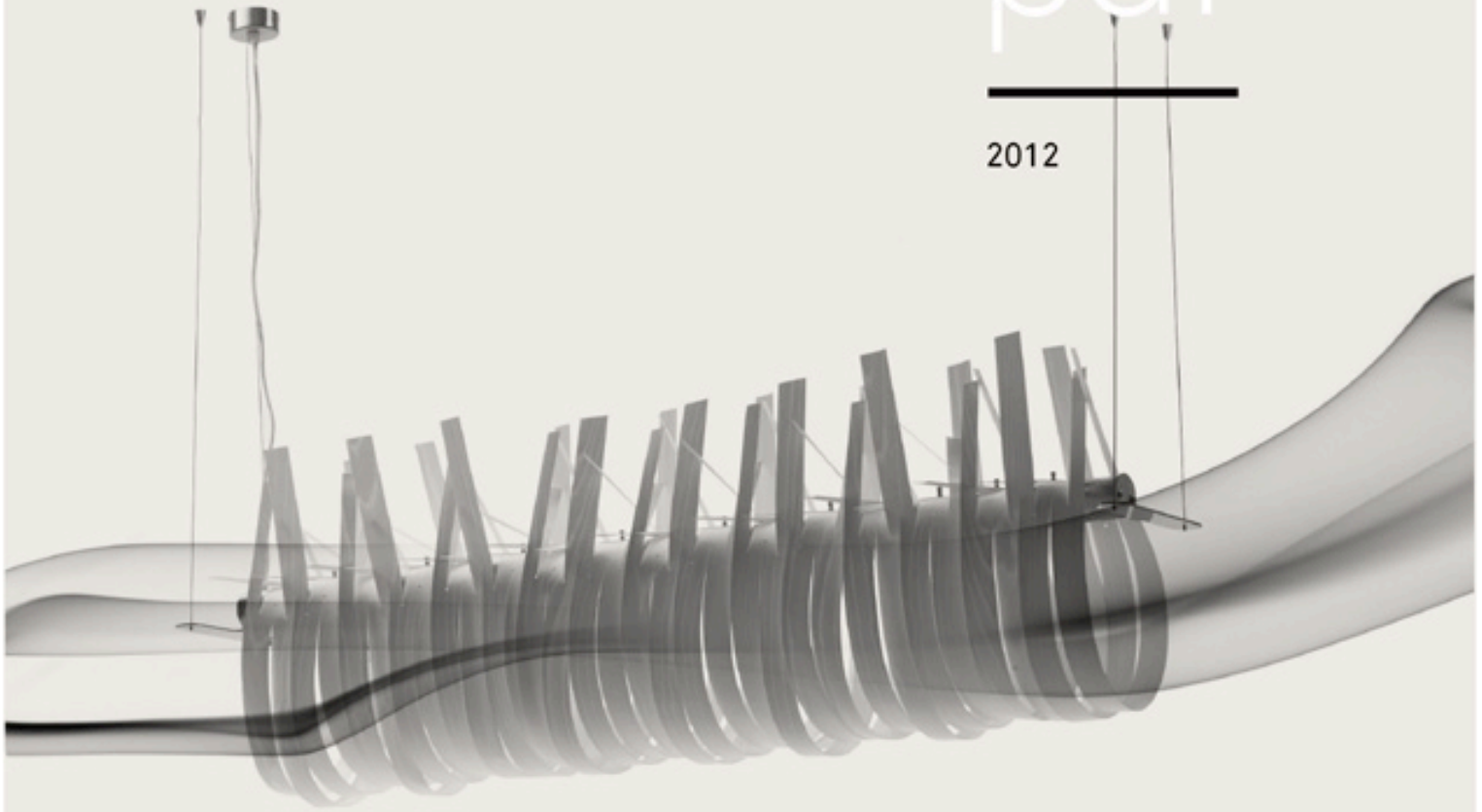

Wood touched by Light





Miguel Herranz

### **Sioux, an air of colour**

Sioux is made up of a series of strips that can be put together to create one-colour, two-colour or multi-colour compositions.

Its shade is made up of several die-cut wood stripes arranged in a way that it reminded us of Native American feather headdresses.

The lightweight shade contrasts with the solid metal structure: warmth against coldness, retro conjugated with techno.

The Sioux family is a creation of Spanish designer Miguel Herranz and is a perfect choice for many decorating style and offers a wide range of design possibilities: the look of several lamps joined together is really impressive.

### **Sioux, aires de color**

*Sioux es una familia de lámparas que permite crear composiciones monocolor, bicolor o multicolor.*

*Su pantalla se realiza con varias tiras de madera troquelada dispuestas de tal manera que nos recuerdan inevitablemente a los tocados de pluma de los indios americanos.*

*La relación entre la pantalla y la estructura metálica es de contrastes: la ligereza de la pantalla frente a la contundencia de su estructura, lo cálido frente a lo frío, lo retro y artesanal conjugado con lo tecno.*

*La familia Sioux está diseñada por el español Miguel Herranz y está pensada para poder componerse también en grandes grupos de lámparas para espacios públicos. Se trata de un sistema modular que permite anclajes a techo y a pared. De este modo se ofrece una solución para todo tipo de interiorismos y posibilidades de diseñar grandes grupos de lámparas para conseguir una imagen final impactante.*

**SIoux** Miguel Herranz

FAMILY / FAMILIA

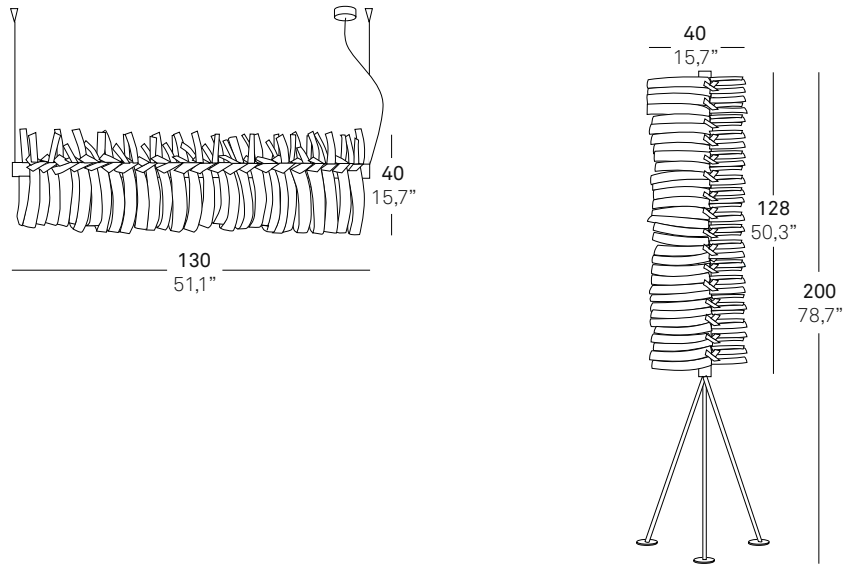

SHADE FINISHES / ACABADOS PANTALLAS

REF. CHW

Natural timber veneer **Madera natural**

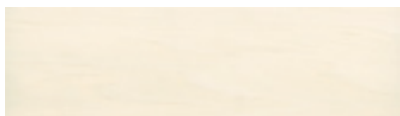

**CHW-20**  
American white wood  
**Bolivar blanco**

**CHW-25**  
Orange  
**Naranja**

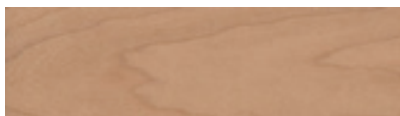

**CHW-21**  
Cherry  
**Cerezo**

**CHW-26**  
Red  
**Roja**



**CHW-22**  
Beech  
**Haya**

**CHW-27**  
Green  
**Verde**



**CHW-24**  
Yellow  
**Amarillo**

**CHW-29**  
Grey  
**Gris**



**Sioux**  
Miguel Herranz

**SIoux** Miguel Herranz

SUSPENSION  
SUSPENSIÓN

INFO

Electrical

Packaging

Dimension

SX SH CHW



Shade / Pantalla

Natural wood /  
**Madera natural**  
CHW colors:

20 21 22 24  
25 26 27 29  
see chart / **ver gráfico**

Multicolor version /  
**Versión multicolor**

FLOOR / PIE

Required / **Requiere**  
shade to base mount /  
**montaje de pantalla**  
a base

**WORLD**

4 x 20 w  
E-27  
Ø95  
CFL globe /  
**Globo bajo consumo**

**USA**

4 x Globe CFL 18W  
Medium Base  
or  
4 x G-25 60W max.  
incandescent

Up-Charge Option

4 x 18W CFL GU-24



Box / **Caja:**  
7,1 Kg  
0,135 m<sup>3</sup>  
30x30x150 cm

18 Lb  
12x12x59"

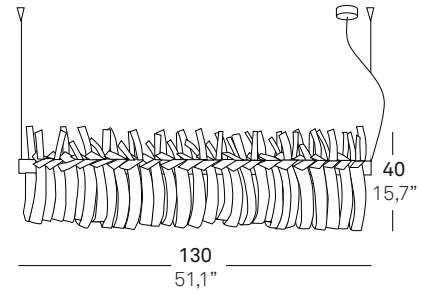

FLOOR  
PIE

SX P CHW



Family / **Familia**  
pendant and floor /  
**susp y pie**

**WORLD**

4 x 20 w  
E-27  
Ø95  
CFL globe /  
**Globo bajo consumo**

**USA**

4 x Globe CFL 18W  
Medium Base  
or  
4 x G-25 60W max.  
incandescent

Up-Charge Option

4 x 18W CFL GU-24



Shade / **Pantalla**  
box 1 / **caja 1:**  
9 Kg  
0,135 m<sup>3</sup>  
30x30x150cm

Foot / **Pie**  
box 2 / **caja 2:**  
7 Kg  
0,225 m<sup>3</sup>  
50x50x78 cm

Shade (box 1)  
16 Lb  
12x12x59"

Foot (box 2)  
14 Lb  
20x20x31"

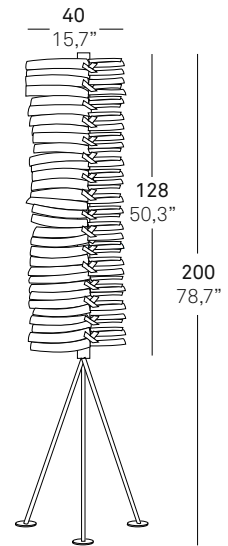





**Sioux**  
Miguel Herranz



**Sioux**  
Miguel Herranz



**Sioux**  
Miguel Herranz



**Sioux**  
Miguel Herranz



**Sioux**  
Miguel Herranz



Sioux  
Miguel Herranz



**Sioux**  
Miguel Herranz



SPANISH  
ARTISAN  
OF THE YEAR  
AWARD 2011