



lzf
HANDMADE

SATURNIA
Book

pdf

2012

Wood touched by Light



SATURNIA

Oskar Cerezo

Saturnia, astronomical rings

Saturnia is a lamp family of clean, soft lines, made up of hanging lamps and designed by Basque-Swiss designer Óskar Cerezo for LZF Lamps. Its name and shape are reminiscent of Planet Saturn, the only planet whose rings can be seen from the Earth.

On one side, the light passing through the wood sheets creates a warm ambience. On the other, the plexiglas diffuser allows for a good working light. Moreover, it incorporates state-of-the-art electronic technology that assures a minimum electrical consumption and is a perfect choice for direct as well and indirect lighting, both in private homes or contract.

Saturnia, anillos astronómicos

Saturnia es una familia de líneas claras y suaves compuesta por lámparas de suspensión diseñadas por el vasco-suizo Óskar Cerezo para LZF Lamps. Su nombre y su forma nos recuerda al planeta Saturno, que curiosamente es el único cuyos anillos son visibles desde la Tierra.

Por un lado, la iluminación difusa que se distribuye entre las chapas de madera, crea una agradable luz ambiental. Por otro lado, el difusor de metacrilato ofrece una buena luz de trabajo.

Equipada con tecnología electrónica para asegurar un mínimo consumo de energía es apta para la iluminación directa e indirecta de espacios privados y de contract.

SATURNIA Oskar Cerezo

FAMILY / FAMILIA

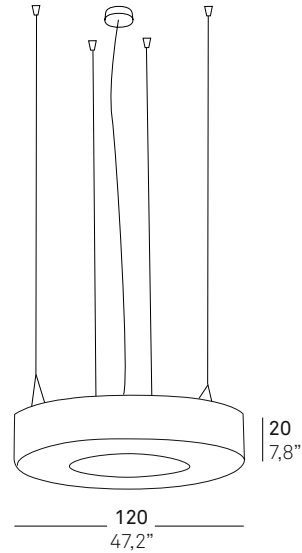
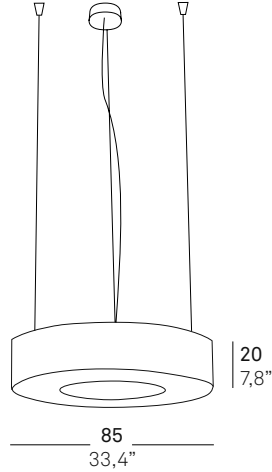
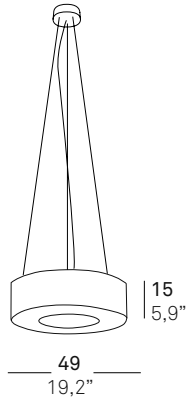

SHADE FINISHES / ACABADOS PANTALLAS

REF. CHW

Natural timber veneer **Madera natural**

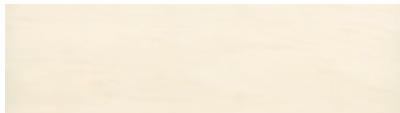

CHW-20
American white wood
Bolivar blanco

CHW-25
Orange
Naranja

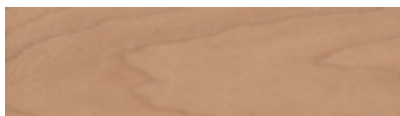

CHW-21
Cherry
Cerezo

CHW-26
Red
Roja



CHW-22
Beech
Haya

CHW-27
Green
Verde



CHW-24
Yellow
Amarillo

CHW-29
Grey
Gris



Saturnia
Oskar Cerezo

SATURNIA Oskar Cerezo

SUSPENSION
SUSPENSIÓN

INFO

Electrical

Packaging

Dimension

SAT S CHW



Shade / Pantalla

Natural wood /
Madera natural
CHW colors:



20 21 22 24



25 26 27 29

see chart / ver gráfico

Diffuser / Difusor
opal acrylic /
metacrilato opal

Consult for price on
dimable version
Electronic ballast
Dali compatible /

**Consultar precio
para versión dimable**
Balastro electrónico
Dali compatible



WORLD

1 x 60 w
T-5
Round fluorescent
included /
**Fluorescente redondo
incluido**



USA

4 x 18W
CFL 4 pin
Quad Tube

110v - 277v
multivolt ballast



Box / Caja:
5,6 Kg
0,115 m³
60x60x32cm

13 Lb
Box size:
24x24x13"



SAT SM CHW



WORLD

3 x 24 w
T-5
Linear fluorescent
included /
**Fluorescente lineal
incluido**

USA

3 x 14 w
T-5
Linear fluorescent
not included

110v - 277v
multivolt ballast



Box / Caja:
15 Kg
0,422 m³
101x102x41 cm

33 Lb
Box size:
40x40x16"

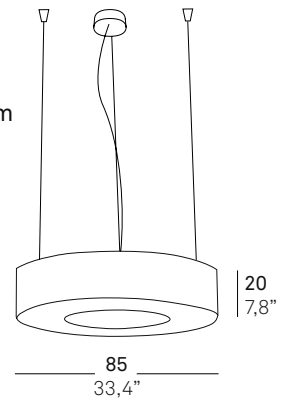

SAT SG CHW



WORLD

4 x 24 w
T-5
Linear fluorescent
included /
**Fluorescente lineal
incluido**

USA

4 x 14 w
T-5
Linear fluorescent
not included

110v - 277v
multivolt ballast



Box / Caja:
47 Kg
0,490 m³
130x130x29 cm

104 Lb
Box size:
51x51x11"

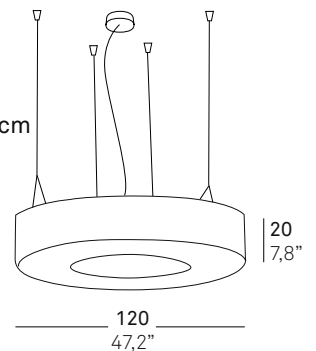

Saturnia
Oskar Cerezo





Saturnia
Oskar Cerezo



Saturnia
Oskar Cerezo



Saturnia
Oskar Cerezo



Saturnia
Oskar Cerezo

lzf

Handmade

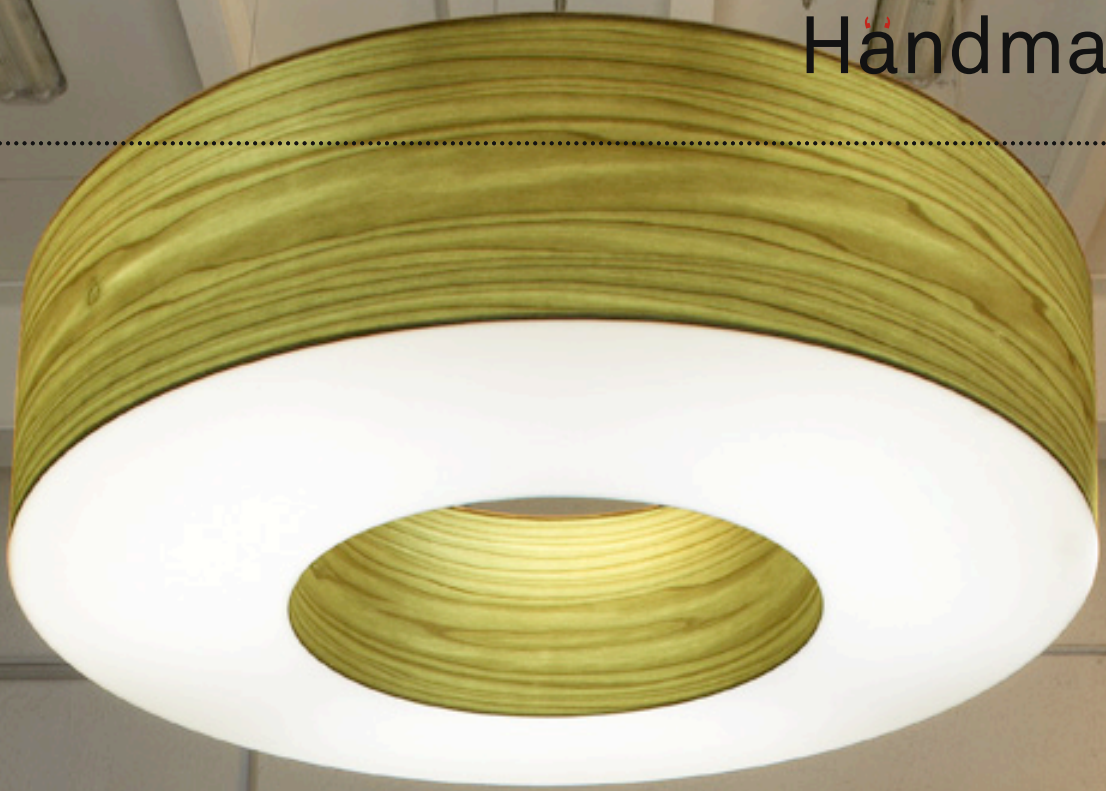

Saturnia
Oskar Cerezo



SPANISH
ARTISAN
OF THE YEAR
AWARD 2011