

lzf
HANDMADE

NUT / ORBIT
Book

pdf

2012

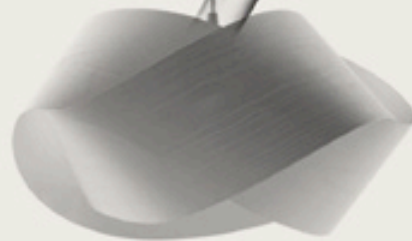

Wood touched by Light



ORBIT/NUT

Miguel Herranz/Lzf Lamps

Nut, a simple tissue

Nut is a hanging lamp from the Orbit family. It features a quite simple intertwined design that results in a very elegant appearance that transmits continuity. Thanks to the use of wood veneer the lamp offers a special warmth which is its main asset.

Nut is Greek for "Goddess of the Sky". Its form and etymology reminiscent of a knot, hence its name, knot in Valencian. It was designed by Luzifer workshop in an attempt to explore and show the virtues of Polywood®. Perfect for private or commercial areas.

Orbit: sweeping, warm comfort

Orbit is a handmade wall lamp created by Spanish designer Miguel Herranz for LZF. With its intertwined pieces of wood veneer a clean, elegant figure eight shape is achieved.

Such simplicity of forms gives birth to a lightweight object with a minimum of material: just what Orbit needs to offer that warm quality of light and create a unique environment, a pleasant and homely atmosphere.

The name gives us an idea of its performance in virtually every interior: the lamp will be by our side as a guardian, keeping us comfortable and cosy with its warm light.

Nut, tejido sencillo

Nut es una lámpara de suspensión que pertenece a la familia Orbit. Un entrelazado sencillo y un resultado final elegante que transmite continuidad. Por un lado, su apariencia ligera, y por otro, la calidez lograda con el uso de la chapa de madera.

Nut, que en griego significa "Diosa del cielo", recuerda formalmente – ¡incluso etimológicamente! – a un "nudo". Es un diseño de Taller Luzifer y un ejercicio para resaltar y descubrir las virtudes del Polywood®.

Es una luminaria apta para espacios de hogar y comerciales.

Orbit, envolvente comodidad

Orbit es un aplique hecho a mano, creado por el español Miguel Herranz para LZF. Su chapa de madera entrecruzada, le confiere una silueta limpia y elegante.

La ligereza se logra por la sencillez de su forma y el uso mínimo de material, justo para conferirle un aspecto cálido. Orbit es capaz de crear a su alrededor un ambiente único, envolvente y hogareño.

De su nombre se intuye la función que puede desempeñar en todo tipo de interiorismo: la lámpara se sitúa a nuestro lado y vela por nuestra comodidad y agradable visibilidad.

ORBIT/NUT Miguel Herranz/Lzf Lamps

FAMILY / FAMILIA

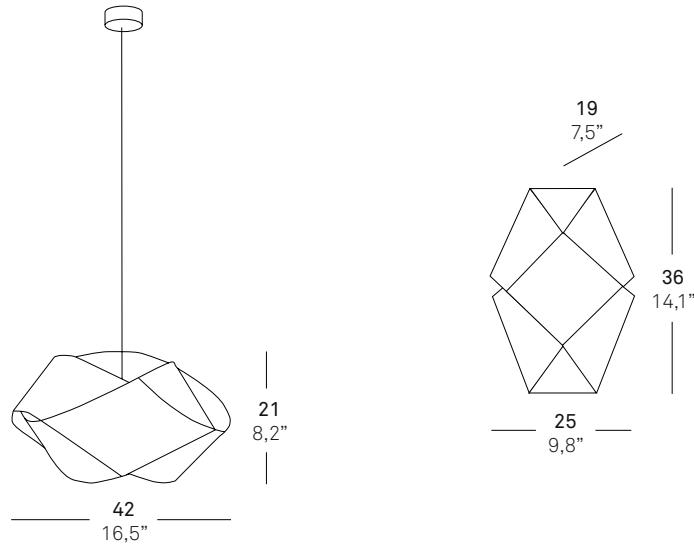

SHADE FINISHES / ACABADOS PANTALLAS

REF. CHW

Natural timber veneer **Madera natural**

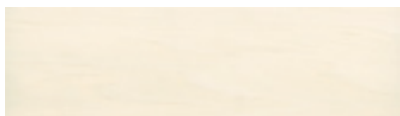

CHW-20
American white wood
Bolivar blanco

CHW-25
Orange
Naranja

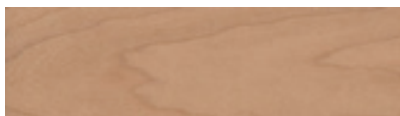

CHW-21
Cherry
Cerezo

CHW-26
Red
Roja



CHW-22
Beech
Haya

CHW-27
Green
Verde



CHW-24
Yellow
Amarillo

CHW-29
Grey
Gris



Orbit/Nut
Miguel Herranz/Lzf Lamps

ORBIT/NUT Miguel Herranz/Lzf Lamps

SUSPENSION SUSPENSIÓN	INFO	Electrical	Packaging	Dimension
--------------------------	------	------------	-----------	-----------

NUTS CHW



Shade / Pantalla
 Natural wood /
Madera natural
 CHW colors:
 20 21 22 24
 25 26 27 29
 see chart / ver gráfico

Family / Familia
 pendant and wall /
 susp y aplique

WORLD
 1 x 20 w
 E-27
 Ø95
 CFL globe /
Globo bajo consumo

USA
 1 x Globe CFL 15W
 Medium Base
 or
 1 x G-25 60W max.
 incandescent

Up-Charge Option
 1 x 15W CFL GU-24



Box / Caja:
 3 Kg
 0,075 m³
 50x50x30 cm

7 Lb
 Box size:
 20x20x12"

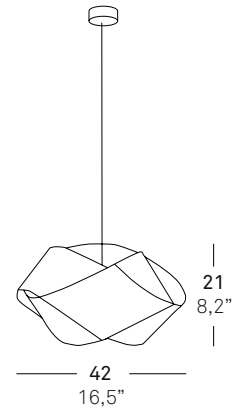

WALL
 APLIQUE

ORB A CHW



WORLD
 1 x 11 w
 E-27
 CFL Double tube /
Bajo consumo

USA
 1 x Globe CFL 15W
 Medium Base
 or
 1 x A-19 60W max.
 incandescent

Up-Charge Option
 1 x Spiral CFL 13W
 GU-24 Base



Box / Caja:
 1,5 Kg
 0,034 m³
 42x30x27 cm

4 Lb
 Box size:
 11x17x12"

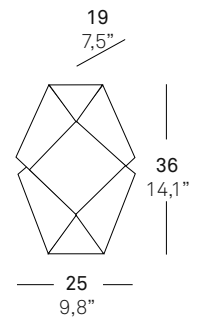



Orbit/Nut
Miguel Herranz/Lzf Lamps



Orbit/Nut
Miguel Herranz/Lzf Lamps



Orbit/Nut
Miguel Herranz/Lzf Lamps



Orbit/Nut
Miguel Herranz/Lzf Lamps



Orbit/Nut
Miguel Herranz/Lzf Lamps



Orbit/Nut
Miguel Herranz/Lzf Lamps



Orbit/Nut
Miguel Herranz/Lzf Lamps

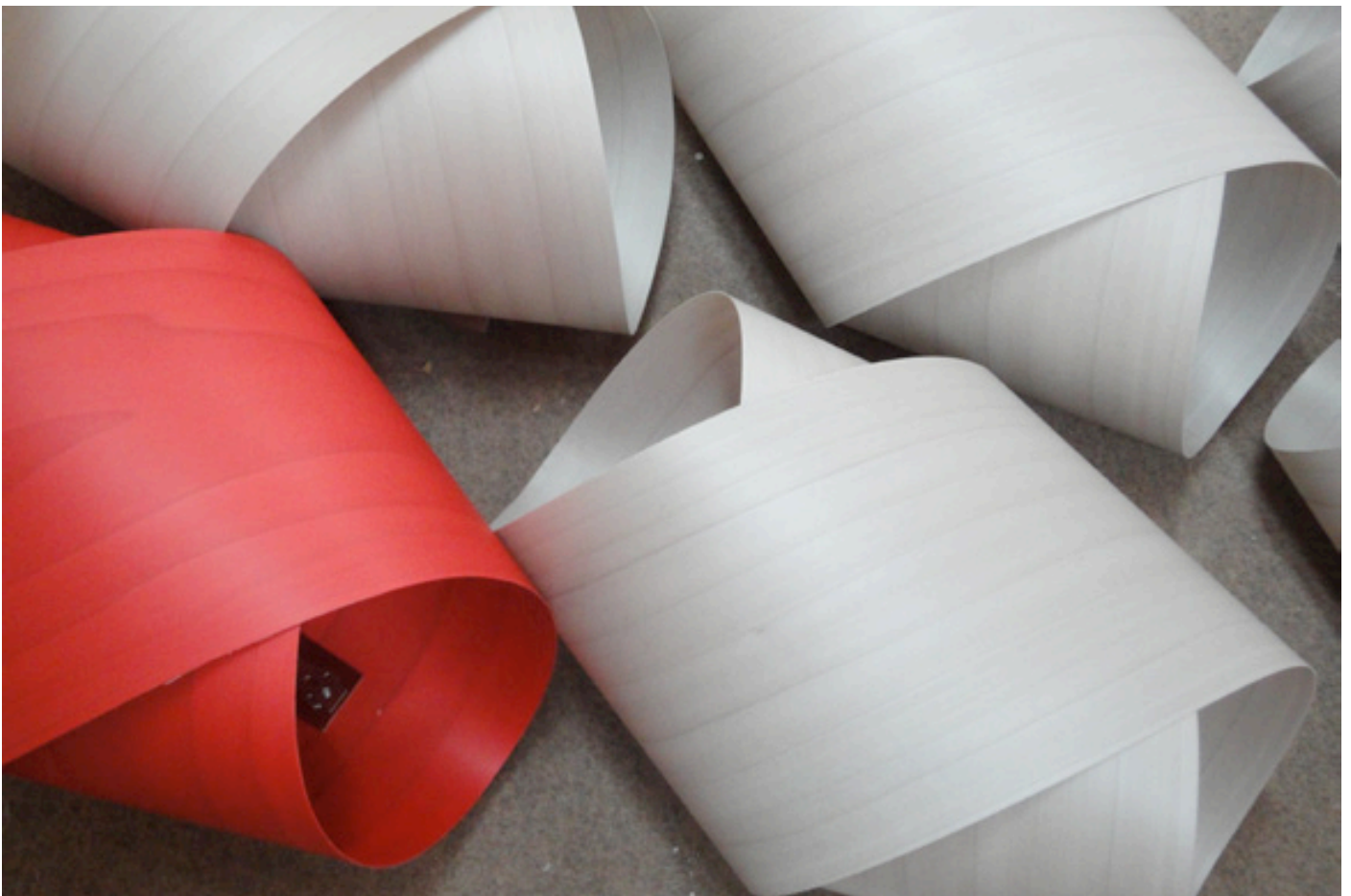



SPANISH
ARTISAN
OF THE YEAR
AWARD 2011