

lzf  
HANDMADE

HOLA  
Book

---

pdf

---

2012

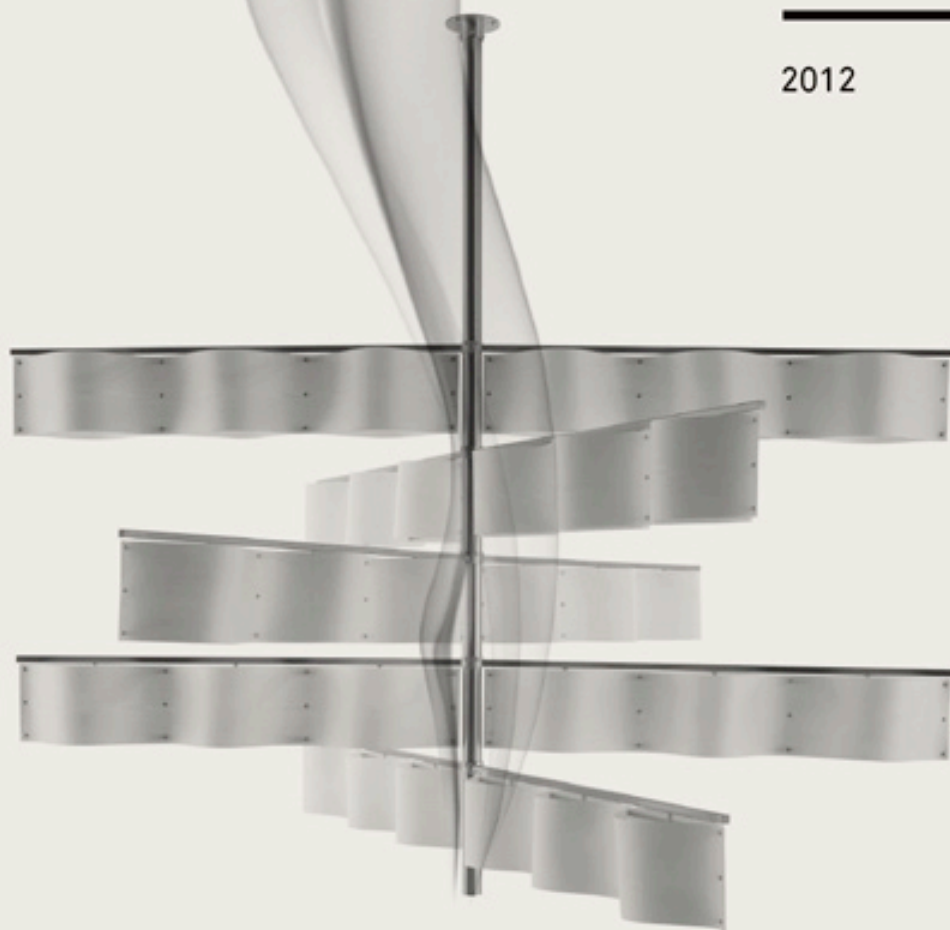

Wood touched by Light





**HOLA/HOLA MASTIL**

---

Miguel Herranz

**Hola, expansive waves**

Hola, a creation by Spanish designer Miguel Herranz, is a hanging lamp made up of two sheets of wood veneer. These are structured in a way that convertes them into a shade made up of three waves for three aligned light points. The result is an elegant and genuine object that can grow in different directions (see the Hola Mástil).

It's design is easily adapted to private homes or commercial areas. The hola can be assembled in structures built around a central mast to create a set of lamps with a strong character, perfect for public areas, receptions areas, bars, restaurants, corridors, and so on.

**Hola, ondas expansivas**

*Hola, diseñada por el español Miguel Herranz, es una lámpara de suspensión compuesta por dos chapas de madera que gracias a sus flexiones “apantallan” tres puntos de luz en línea. De este modo se obtiene un elemento elegante y genuino que, además, puede crecer longitudinalmente o en otras direcciones (ver Hola Mástil).*

*De diseño adaptable al hogar y de enormes posibilidades para espacios comerciales, Hola permite configurar grandes grupos de lámparas anclando pantallas horizontalmente (en el tubo superior) y obtener un efecto de continuidad total de ondas y de iluminación. De este modo se obtienen grupos de lámparas con fuerte y contundente presencia para espacios públicos, como por ejemplo recepciones, barras de bares-restaurantes, pasillos, etc.*

**HOLA/HOLA MASTIL Miguel Herranz**

SUSPENSION  
SUSPENSIÓN

INFO

Electrical

Packaging

Dimension

**OLA S CHW**



Shade / Pantalla

Natural wood /  
**Madera natural**  
CHW colors:



20 21 22 24  
25 26 27 29  
see chart /  
**ver gráfico**

Required /  
**Requiere**  
shade mounting /  
**montaje de**  
**pantalla**

**WORLD**



3 x 11 w  
E-27  
CFL short  
Double tube /  
**Bajo consumo**

Box / **Caja**:  
4,3 Kg  
0,115 m<sup>3</sup>  
120x30x32 cm

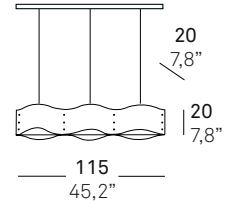

**USA**



3 x Globe CFL 15W  
Medium Base  
or  
3 x G-25 100W max.  
incandescent

10 Lb  
Box size:  
47x12x13"



**Up-Charge Option**  
3 x Spiral CFL 15W  
GU-24 Base



**OLA+2 S CHW**



**WORLD**



6 x 11 w  
E-27  
CFL short  
Double tube /  
**Bajo consumo**

**Shades / Pantallas**  
boxes 1-2 /  
**cajas 1-2:**  
4,3 Kg/each (ud)  
0,115 m<sup>3</sup>/each (ud)  
120x30x32 cm/each (ud)

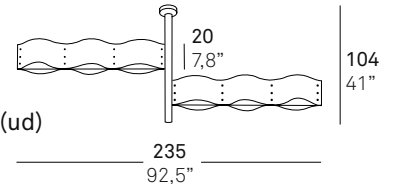

**Mast / Mástil**  
box 3 / **caja 3:**  
6 Kg  
0,115 m<sup>3</sup>  
120x30x32 cm

**USA**



6 x Globe CFL 15W  
Medium Base  
or  
6 x G-25 100W max.  
incandescent

Shades (box 1-2):  
10 Lb/each.  
Box size:  
47x12x13"/each.



**Up-Charge Option**  
6 x Spiral CFL 15W  
GU-24 Base

Mast (box 3):  
14 Lb  
Box size:  
47x12x13"



**HOLA/HOLA MASTIL Miguel Herranz**

SUSPENSION  
SUSPENSIÓN

INFO

Electrical

Packaging

Dimension

**OLA+10 S CHW**

Shade / Pantalla

Natural wood /  
**Madera natural**  
CHW colors:

  
 20 21 22 24  
 25 26 27 29  
 see chart /  
**ver gráfico**

Required /  
**Requiere**  
shade mounting /  
**montaje de**  
**pantalla**



**WORLD**

30 x 11 w  
E-27  
CFL short  
Double tube /  
**Bajo consumo**



**USA**

30 x Globe CFL 15W  
Medium Base  
or  
30 x G-25 100W max.  
incandescent



**Up-Charge Option**

30 x Spiral CFL 15W  
GU-24 Base



Shades / **Pantallas**

boxes 1-10 /  
**cajas 1-10:**  
43 Kg/each (ud)  
0,115 m<sup>3</sup>/each (ud)  
120x30x32 cm/each (ud)

**Mast / Mástil**  
box 11 / **caja 11:**  
12 Kg  
0,072 m<sup>3</sup>  
230x10x10 cm

Shades (box 1-10):  
10 Lb/each  
Box size:  
47x12x13"/each

Mast (box 11):  
27 Lb  
Box size:  
91x4x4"

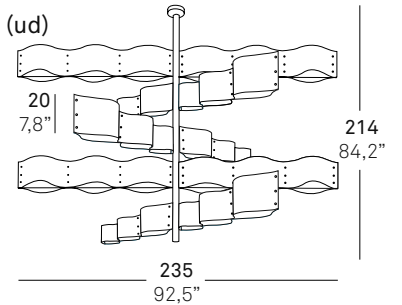

HOLA/HOLA MASTIL Miguel Herranz



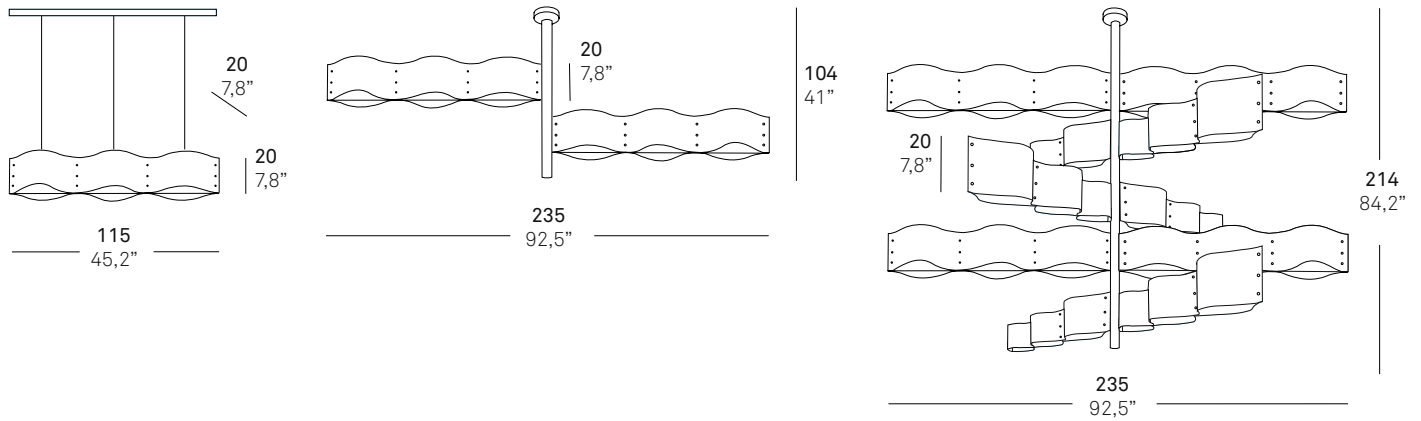





FAMILY / FAMILIA

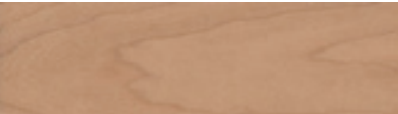

SHADE FINISHES / ACABADOS PANTALLAS

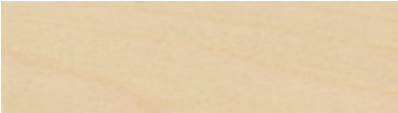
REF. CHW

Natural timber veneer **Madera natural**

	<b>CHW-20</b> American white wood Bolivar blanco		<b>CHW-25</b> Orange Naranja
	<b>CHW-21</b> Cherry Cerezo		<b>CHW-26</b> Red Roja
	<b>CHW-22</b> Beech Haya		<b>CHW-27</b> Green Verde
	<b>CHW-24</b> Yellow Amarillo		<b>CHW-29</b> Grey Gris



**Hola/Hola Mastil**  
Miguel Herranz



Hola/Hola Mastil  
Miguel Herranz



**Hola/Hola Mastil**  
Miguel Herranz



Hola/Hola Mastil  
Miguel Heranz



**Hola/Hola Mastil**  
Miguel Herranz



**Hola/Hola Mastil**  
Miguel Herranz



**Hola/Hola Mastil**  
Miguel Herranz





SPANISH  
ARTISAN  
OF THE YEAR  
AWARD 2011